

# Applying Aruba Switching Fundamentals for Mobility

## Exam description

This exam tests your knowledge of the features, benefits, and functions of Aruba networking components and technologies used in the Aruba Mobile-First architecture. This exam tests your ability to implement and validate a basic secure wired and wireless network with the use of ArubaOS switches, CLI, various technologies, and Aruba Instant Access Points (IAPs). This exam also tests your ability to manage and monitor the network with AirWave.

## Ideal candidate for this exam

Typical candidate is a technical professional who has at least six months experience with small to medium enterprise level network deployments. The candidate also demonstrates knowledge of wired technologies used in edge and simple core environments, and fundamental knowledge of wireless technologies; 802.11a/b/g/n/ac, basic RF interactions and issues, and basic wireless security methods.

## Exam contents

This exam has 60 questions.

## Advice to help you take this exam

- Complete the training and review all course materials and documents before you take the exam.
- Exam items are based on expected knowledge acquired from job experience, an expected level of industry standard knowledge, or other prerequisites (events, supplemental materials, etc.).
- Successful completion of the course alone does not ensure you will pass the exam.
- Read this HPE Exam Preparation Guide and follow its recommendations.
- Visit HPE Press for additional reference materials, study guides, practice tests, and HPE books.

## Related certifications

- Aruba Certified Switching Associate (ACSA) V1

## Supporting resources

These recommended resources help you prepare for the exam:

Resource Type	Resource ID	Resource Name
Course	01077931	01077931: Aruba Switching Fundamentals, Rev. 16.41

## Additional study materials

- Aruba Certified Switching Associate Study Guide

## Objectives

This exam validates that you can:

<b>Exam ID</b>	HPE6-A41
<b>Exam type</b>	Proctored
<b>Exam duration</b>	1 hour 55 minutes
<b>Exam length</b>	60 questions
<b>Passing score</b>	68%
<b>Delivery languages</b>	English, Japanese
<p>Register for this Exam You need an HPE Learner ID and a Pearson VUE login and password.</p> <p>No reference material is allowed at the testing site. This exam may contain beta test items for experimental purposes.</p> <p>During the exam, you can make comments about the exam items. We welcome these comments as part of our continuous improvement process.</p>	

Sections/Objectives	
40%	<p>Identify, describe, and apply foundational networking architectures and technologies.</p> <ul style="list-style-type: none"> <li>Describe the basics of Layer 2 Ethernet to include broadcast domains and ARP messages.</li> <li>Interpret an IP routing table and explain default routes, static routing, and dynamic routing such as OSPF.</li> <li>Identify the roles of TFTP, SFTP, FTP, Telnet, SNMPv2, and SNMPv3 in the management of Aruba network devices, and apply the appropriate security for these features.</li> <li>Describe Layer 2 redundancy technologies such as STP, RSTP, MSTP and VSF, and recognize the benefits of each.</li> <li>Describe and apply link aggregation.</li> <li>Identify, describe, and explain VLANs.</li> <li>Describe, identify, and explain wireless technologies.</li> </ul>
8%	<p>Identify, describe, and differentiate the functions and features of Aruba products and solutions.</p> <ul style="list-style-type: none"> <li>Identify and explain how Aruba, a Hewlett Packard Enterprise company, delivers solutions that enable the digital workplace.</li> <li>Identify basic features and management options for Aruba wired and wireless products.</li> <li>Compare and contrast Aruba Networking solutions and features, and identify the appropriate product for an environment.</li> </ul>
37%	<p>Install, configure, set up, and validate Aruba networking solutions.</p> <ul style="list-style-type: none"> <li>Configure basic features on ArubaOS switches to include initial settings and management access.</li> <li>Configure ArubaOS switches with Layer 2 technologies such as RSTP and MSPT, link aggregation, VLANs, LLDP, and device profiles.</li> <li>Configure basic IP routing with static routes or OSPF on ArubaOS switches.</li> <li>Manage the software and configuration files on ArubaOS switches, and manage ArubaOS switches and APs with Aruba AirWave.</li> <li>Validate the installed solution with the use of debug technology, logging, and show and display commands.</li> </ul>
5%	<p>Tune, optimize, and upgrade Aruba networking solutions.</p> <ul style="list-style-type: none"> <li>Optimize Layer 2 and Layer 3 infrastructures through broadcast domain reduction, VLANs, and VSF.</li> </ul>
10%	<p>Manage, monitor, administer, and operate Aruba networking solutions.</p> <ul style="list-style-type: none"> <li>Perform network management in accordance with best practices.</li> <li>Perform administrative tasks such as moves, adds, changes, deletions, and password resets for managed devices.</li> </ul>

## Sample questions

Sample questions are provided only as examples of question style, format and complexity/difficulty. They do not represent all question types and do not reflect all topic areas. These sample questions do not represent a practice test.

### 1. Objective: Describe and apply link aggregation

Refer to the exhibit.

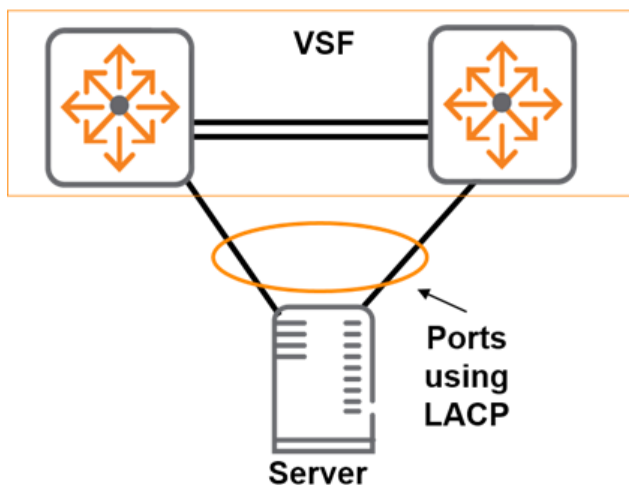

The server shown in the exhibit requires redundant links, and the server ports are set up to use LACP. What should the administrator configure on the VSF fabric?

- Two separate interfaces that are in the same VLAN
- a static LACP link aggregation
- Two separate interfaces with LACP passive mode enabled on them

d. a distributed link aggregation that uses LACP

2. Objective: Manage the software and configuration files on ArubaOS switches, and manage ArubaOS switches and APs with Aruba AirWave.

Refer to the exhibit.

```
Switch-1# show version
Image stamp:
 /ws/swbuildm/rel_richmond_qaoff/code/build/tam(swbuildm_rel_richmond_qaoff_rel_
 richmond)
           Mar 23 2016 11:47:03
           KA.16.01.0006
           432
Boot Image:   Primary

Boot ROM Version:   KA.15.09
Active Boot ROM:   Primary
```

What can a network administrator determine from the output shown in the exhibit?

- a. The switch will boot the primary software on its next boot.
- b. The switch has no software stored in the secondary slot.
- c. The switch uses the config file in the primary slot for its startup-Config.
- d. The switch booted the primary software on its previous boot.

3. Objective: Configure basic features on ArubaOS switches and APs to include initial settings and management access.

What is the role of the default Instant SSID on an Aruba Instant AP?

- a. It automatically implements the highest level of security for employees.
- b. It provides administrators with a dedicated SSID to manage the Instant cluster on an ongoing basis.
- c. It allows administrators to complete initial provisioning and is then automatically deleted.
- d. It provides a dedicated control channel for Instant APs to communicate with each other and the VC.

4. Objective: Identify the roles of TFTP, SFTP, FTP, Telnet, SNMPv2, and SNMPv3 in the management of Aruba network devices, and apply the appropriate security for these features.

A network administrator needs to restrict access to the console port of an ArubaOS switch. When a user connects to the console port and opens a terminal session, the switch should prompt the user for a username and password. The user should be able to skip authentication and receive access to basic mode. However, if the user attempts to reach enable mode, the user should be forced to enter the correct username and password.

What should the network administrator configure on the switch to meet these requirements?

- a. an operator password only
- b. an operator password and a manager password
- c. a manager password only
- d. two operator passwords with different usernames

5. Objective: Configure basic IP routing with static routes or OSPF on ArubaOS switches.

An administrator configures OSPF on an ArubaOS switch. What is one of the steps that the administrator must take?

- a. Create an OSPF area before a VLAN interface is assigned to that area.
- b. Set a global router ID before OSPF is enabled.
- c. The administrator must set an OSPF router ID before OSPF is enabled.
- d. Assign a VLAN interface its IP address before the network it corresponds to is specified in an OSPF area.

6. Objective: Interpret an IP routing table and explain default routes, static routing, and dynamic routing, to include OSPF.

Refer to the exhibits.

Exhibit 1

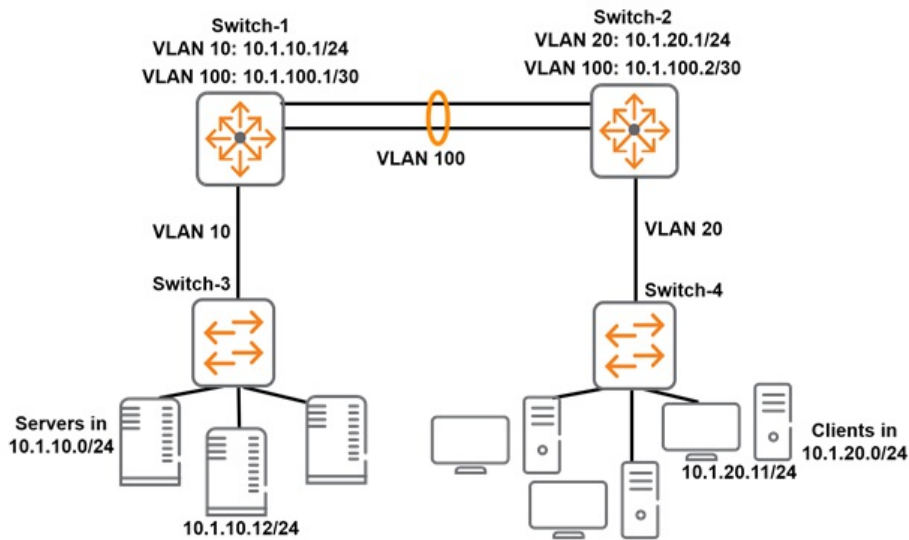

Exhibit 2

```
tracert 10.1.10.12
Tracing route to 10.1.10.12 over a maximum of 30 hops
 1  <1 ms  <1 ms  <1 ms  10.1.20.1
 2  10.1.20.1 reports: Destination net unreachable
```

Switch-1 and Switch-2 have IP routing enabled. Switch-1 should be the default gateway for 10.1.10.0/24, and Switch-2 should be the default gateway for 10.1.20.0/24. The network administrator troubleshoots a connectivity issue between clients in 10.1.20.0/24 and servers in 10.1.10.0/24. The administrator enters a trace route command on client 10.1.20.11 and sees the results shown in Exhibit 2.

What is the most likely solution for the issue?

- a. Enable IP routing on Switch-3 and Switch-4.
- b. Verify that VLAN 20 is correctly tagged on the link between Switch-2 and Switch-4.
- c. Configure a different IP address for the default gateway on 10.1.20.11 and other clients.
- d. Make sure that Switch-2 has a route to 10.1.10.0/24.

7. Objective: Perform network management in accordance with best practices.

AirWave has discovered several ArubaOS switches. What is one AirWave capability that requires the administrator to set the management level for the switches to Manage Read/Write?

- a. Audit the switch software and manage software updates.
- b. Apply configuration changes to the switches with the use of a configuration template.
- c. Check switch configurations against a configuration template.
- d. Monitor the status of interfaces on the switches.

8. Objective: Optimize Layer 2 and Layer 3 infrastructures through broadcast domain reduction, VLANs, and VSF.

A network administrator needs to establish a VSF fabric. The administrator wants to use the fewest number of commands to create the fabric. What are the requirements to set up the VSF link?

- a. Enter a command to set up the VSF link on the future commander but not the future standby member.
- b. Enter a command to set up the VSF link on both the future standby member and the future commander.
- c. Do not enter a command to set up the VSF link on the future commander or the future standby member.
- d. Enter a command to set up the VSF link on the future standby member but not on the future commander.

9. Objective: Describe Layer 2 redundancy technologies such as STP, RSTP, MSTP and VSF, and recognize the benefits of each.

Refer to the exhibit.

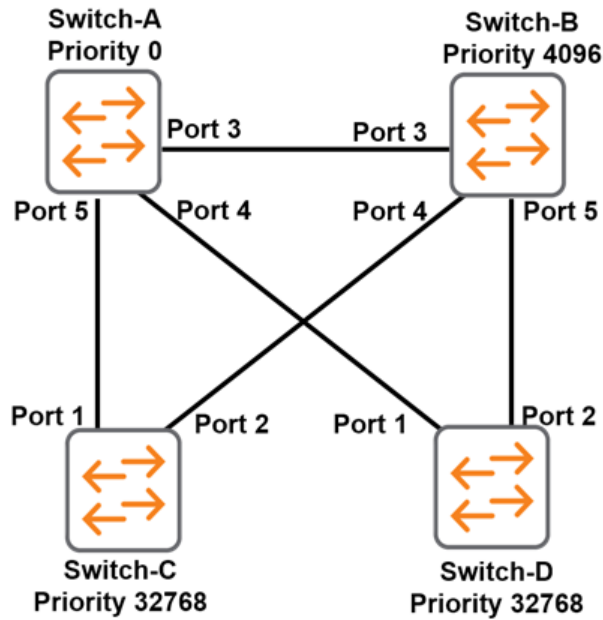

The switches shown in the exhibit run Rapid Spanning Tree Protocol (RSTP). All of the ports shown in the exhibit are 10 Gbps ports, and the switches use the standard port costs. Which port is an alternate port?

- a. Port 1 on Switch-D
- b. Port 2 on Switch-C
- c. Port 4 on Switch-A
- d. Port 4 on Switch-B

## Answers

This section provides answers to and references for the sample questions.

1. Objective: Describe and apply link aggregation

Refer to the exhibit.

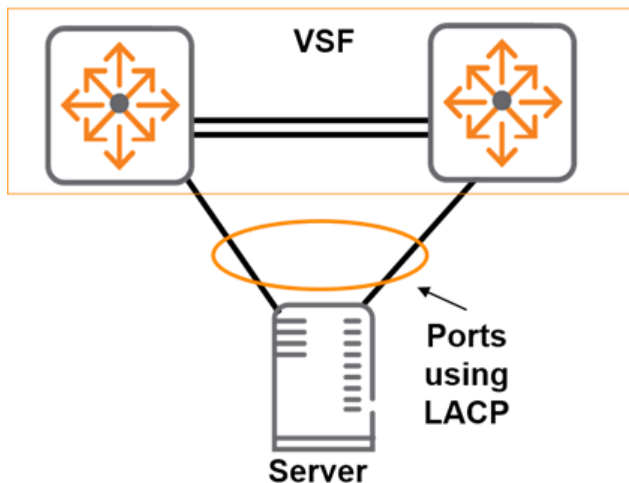

The server shown in the exhibit requires redundant links, and the server ports are set up to use LACP. What should the administrator configure on the VSF fabric?

- a. Two separate interfaces that are in the same VLAN
- b. a static LACP link aggregation
- c. Two separate interfaces with LACP passive mode enabled on them

d. a distributed link aggregation that uses LACP

2. Objective: Manage the software and configuration files on ArubaOS switches, and manage ArubaOS switches and APs with Aruba AirWave.

Refer to the exhibit.

```
Switch-1# show version
Image stamp:
 /ws/swbuildm/rel_richmond_qaoff/code/build/tam(swbuildm_rel_richmond_rel_
 richmond)
           Mar 23 2016 11:47:03
           KA.16.01.0006
           432
Boot Image:   Primary

Boot ROM Version:  KA.15.09
Active Boot ROM:   Primary
```

What can a network administrator determine from the output shown in the exhibit?

- a. The switch will boot the primary software on its next boot.
- b. The switch has no software stored in the secondary slot.
- c. The switch uses the config file in the primary slot for its startup-Config.
- d. The switch booted the primary software on its previous boot.

3. Objective: Configure basic features on ArubaOS switches and APs to include initial settings and management access.

What is the role of the default Instant SSID on an Aruba Instant AP?

- a. It automatically implements the highest level of security for employees.
- b. It provides administrators with a dedicated SSID to manage the Instant cluster on an ongoing basis.
- c. It allows administrators to complete initial provisioning and is then automatically deleted.
- d. It provides a dedicated control channel for Instant APs to communicate with each other and the VC.

4. Objective: Identify the roles of TFTP, SFTP, FTP, Telnet, SNMPv2, and SNMPv3 in the management of Aruba network devices, and apply the appropriate security for these features.

A network administrator needs to restrict access to the console port of an ArubaOS switch. When a user connects to the console port and opens a terminal session, the switch should prompt the user for a username and password. The user should be able to skip authentication and receive access to basic mode. However, if the user attempts to reach enable mode, the user should be forced to enter the correct username and password.

What should the network administrator configure on the switch to meet these requirements?

- a. an operator password only
- b. an operator password and a manager password
- c. a manager password only
- d. two operator passwords with different usernames

5. Objective: Configure basic IP routing with static routes or OSPF on ArubaOS switches.

An administrator configures OSPF on an ArubaOS switch. What is one of the steps that the administrator must take?

- a. Create an OSPF area before a VLAN interface is assigned to that area.
- b. Set a global router ID before OSPF is enabled.
- c. The administrator must set an OSPF router ID before OSPF is enabled.
- d. Assign a VLAN interface its IP address before the network it corresponds to is specified in an OSPF area.

6. Objective: Interpret an IP routing table and explain default routes, static routing, and dynamic routing, to include OSPF.

Refer to the exhibits.

Exhibit 1

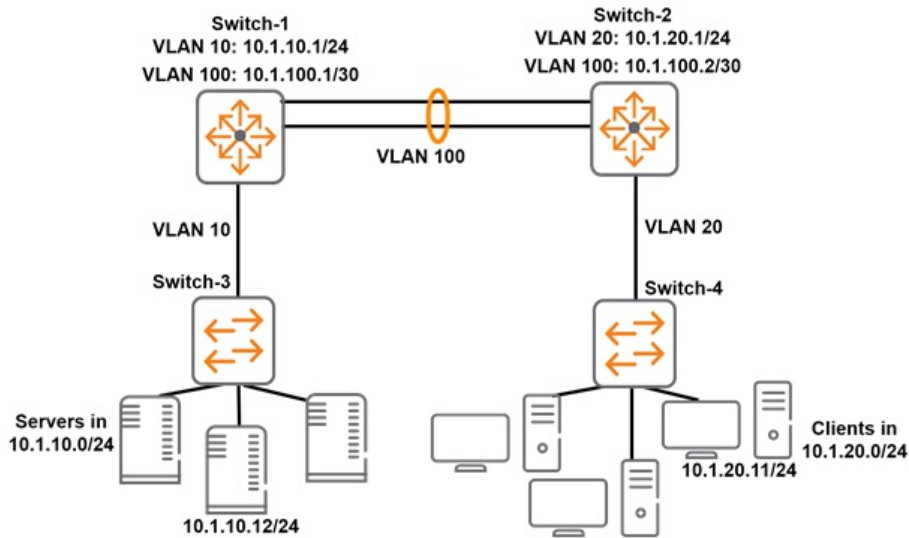

Exhibit 2

```
tracert 10.1.10.12
Tracing route to 10.1.10.12 over a maximum of 30 hops
 1 <1 ms <1 ms <1 ms 10.1.20.1
 2 10.1.20.1 reports: Destination net unreachable
```

Switch-1 and Switch-2 have IP routing enabled. Switch-1 should be the default gateway for 10.1.10.0/24, and Switch-2 should be the default gateway for 10.1.20.0/24. The network administrator troubleshoots a connectivity issue between clients in 10.1.20.0/24 and servers in 10.1.10.0/24. The administrator enters a trace route command on client 10.1.20.11 and sees the results shown in Exhibit 2.

What is the most likely solution for the issue?

- a. Enable IP routing on Switch-3 and Switch-4.
- b. Verify that VLAN 20 is correctly tagged on the link between Switch-2 and Switch-4.
- c. Configure a different IP address for the default gateway on 10.1.20.11 and other clients.
- d. Make sure that Switch-2 has a route to 10.1.10.0/24.

7. Objective: Perform network management in accordance with best practices.

AirWave has discovered several ArubaOS switches. What is one AirWave capability that requires the administrator to set the management level for the switches to Manage Read/Write?

- a. Audit the switch software and manage software updates.
- b. Apply configuration changes to the switches with the use of a configuration template.
- c. Check switch configurations against a configuration template.
- d. Monitor the status of interfaces on the switches.

8. Objective: Optimize Layer 2 and Layer 3 infrastructures through broadcast domain reduction, VLANs, and VSF.

A network administrator needs to establish a VSF fabric. The administrator wants to use the fewest number of commands to create the fabric. What are the requirements to set up the VSF link?

- a. Enter a command to set up the VSF link on the future commander but not the future standby member.
- b. Enter a command to set up the VSF link on both the future standby member and the future commander.
- c. Do not enter a command to set up the VSF link on the future commander or the future standby member.
- d. Enter a command to set up the VSF link on the future standby member but not on the future commander.

9. Objective: Describe Layer 2 redundancy technologies such as STP, RSTP, MSTP and VSF, and recognize the benefits of each.

Refer to the exhibit.

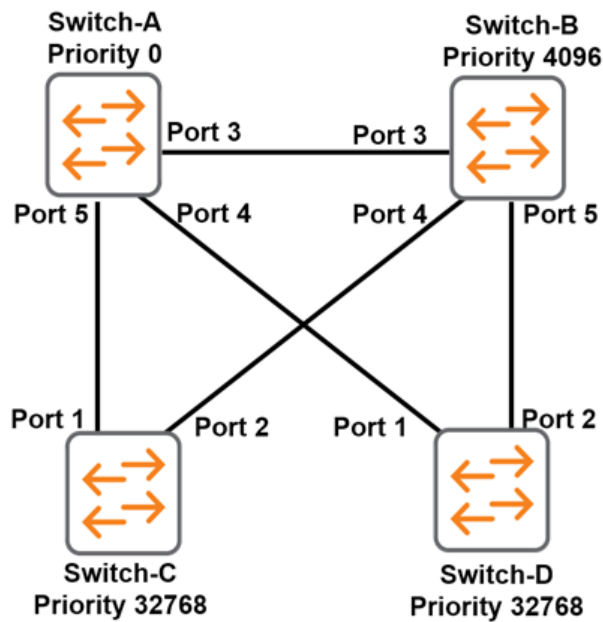

The switches shown in the exhibit run Rapid Spanning Tree Protocol (RSTP). All of the ports shown in the exhibit are 10 Gbps ports, and the switches use the standard port costs. Which port is an alternate port?

- a. Port 1 on Switch-D
- b. Port 2 on Switch-C
- c. Port 4 on Switch-A
- d. Port 4 on Switch-B

## For more information

Contact our program

© Copyright 2019 Hewlett Packard Enterprise. The information contained herein is subject to change without notice. The only warranties for HPE products and services are set forth in the express warranty statements accompanying such products and services. Nothing herein should be construed as constituting an additional warranty. HPE shall not be liable for technical or editorial errors or omissions contained herein.

Information is as of February 2018, Revision 3