

Aruba Certified Design Professional Exam

Exam Description

This exam tests your knowledge, skills, and ability to design solutions based on given requirements and the architectural design. It tests your ability to design solutions for single-site campus networks with less than 1000 employees, or for subsystems or components of enterprise-level wired and wireless campus, branch, and remote networks.

Ideal Candidate For This Exam

Typical candidates for this exam are networking IT professionals who have architect experience with Aruba wireless and wired switching solutions. They have relevant field experience focused on interpreting architectures and customer requirements to design Aruba subsystems or single-site campus network solutions.

Exam Contents

This exam has 60 questions.

Advice To Help You Take This Exam

- Complete the training and review all course materials and documents before you take the exam.
- Exam items are based on expected knowledge acquired from job experience, an expected level of industry standard knowledge, or other prerequisites (events, supplemental materials, etc.).
- Successful completion of the course alone does not ensure you will pass the exam.
- Read this HPE Exam Preparation Guide and follow its recommendations.
- Visit HPE Press for additional reference materials, study guides, practice tests, and HPE books.
- Exam items are of multiple choice format and can include short scenarios, and a few items can be aligned to a main scenario.

Supporting resources

These recommended resources help you prepare for the exam:

Resource Type	Resource ID	Resource Name
Course	0001130961	Designing Aruba Solutions, Rev. 20.11

Additional study materials

- Aruba Certified Design Professional Study Guide

Objectives

This exam validates that you can:

Exam ID	HPE6-A47
Exam type	Proctored
Exam duration	1 hour 30 minutes
Exam length	60 questions
Passing score	68%
Delivery languages	English, Japanese, Latin American Spanish
<p>Register for this Exam You need an HPE Learner ID and a Pearson VUE login and password.</p> <p>No reference material is allowed at the testing site. This exam may contain beta test items for experimental purposes.</p> <p>During the exam, you can make comments about the exam items. We welcome these comments as part of our continuous improvement process.</p>	

Percentage of Exam	Sections/Objectives
10%	Gather and analyze data, and document customer requirements for a single-site campus environment with less than 1000 employees or subsystems of an enterprise-wide network. <ul style="list-style-type: none"> Given an outline of a customer's needs, determine the information required to create a solution.
18%	Evaluate the requirements for a single-site campus environment with less than 1000 employees or subsystems of an enterprise-wide network, and select the wired and wireless networking technologies for the design. <ul style="list-style-type: none"> Given a scenario, evaluate the customer requirements to identify gaps per a gap analysis, and select components based on the analysis results. Given a scenario, translate the business needs of the environment into technical customer requirements.
31%	Plan and design an Aruba solution per the customer requirements for a single-site campus environment with less than 1000 employees or subsystems of an enterprise-wide network. <ul style="list-style-type: none"> Given a scenario, select the appropriate products based on the customer technical requirements. Given the customer requirements, design the high-level architecture. Given a customer scenario, explain how a specific technology or solution would meet the customer requirements.
33%	Produce a detailed design specification document for a single-site campus environment with less than 1000 employees or subsystems of an enterprise-wide network. <ul style="list-style-type: none"> Given a customer scenario, choose the appropriate components that should be included on the BOM. Given the customer requirements, determine the component details and document the high-level design. Given a customer scenario, determine and document a detailed network management design. Given a customer scenario, design and document a detailed network security solution. Given a customer scenario, design and document the logical and physical network solutions. Given the customer scenario and service level agreements, document the licensing and maintenance requirements.
8%	Recommend the solution to the customer. <ul style="list-style-type: none"> Given the customer's requirements, explain and justify the recommended solution.

Sample questions

Sample questions are provided only as examples of question style, format and complexity/difficulty. They do not represent all question types and do not reflect all topic areas. These sample questions do not represent a practice test.

- A customer needs a wireless refresh for 802.11ac. The customer site has about 3,000 wireless devices, and the network architect plans to propose 200 APs. The architect also plans to propose two Virtual Mobility Controllers (VMCs) and a Virtual Mobility Master (VMM). Which licenses should the architect propose for this solution?

 - Four LIC-MM-VA-1K; Four LIC-MC-VA-50; 200 Enterprise
 - Five LIC-MM-VA-50; Four LIC-MC-VA-50; 200 Enterprise
 - Five LIC-MM-VA 50; Four LIC-MC-VA 50 and no Enterprise required
 - Five LIC-MM-VA-50; 200 Enterprise and no LIC-MC-VA required
- For which scenario does an Aruba VIA client provide the solution?

 - A customer needs an easy-to-use wireless solution that enables remote workers to connect to the same SSID at the corporate office and at home.
 - A customer has many telecommuters who take laptops on and offsite and needs a solution to check the security compliance and health of these laptops.
 - A customer needs to let traveling workers connect to the Internet anywhere and receive secure access to the main site.
 - A customer needs a client that will simplify connections to the wireless network at the main site no matter what type of authentication the SSID requires.
- Refer to the exhibit.

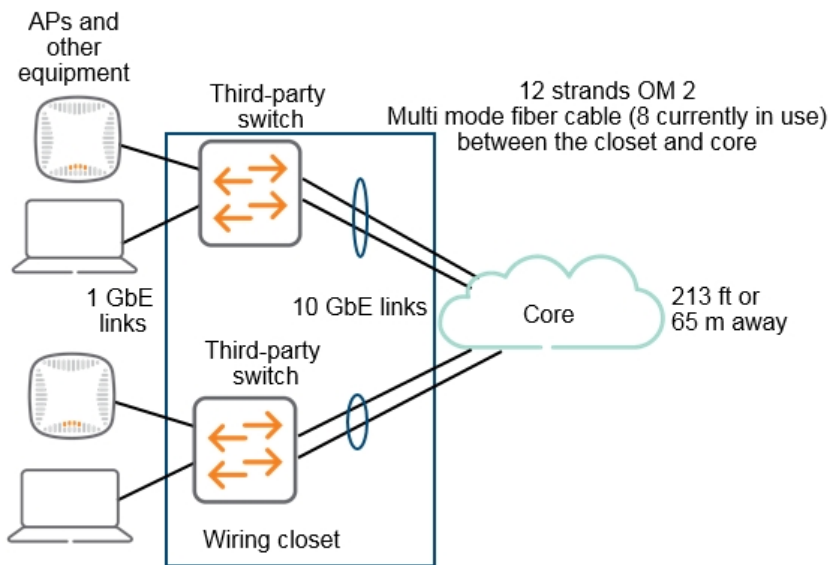

The exhibit shows information about a customer's existing equipment in a closet. The customer needs an upgrade for this closet. The architect plans to:

- Replace the switches with two Aruba 3810M switches
- Connect the 3810M switches in a backplane stack
- Upgrade the uplinks to two 40GbE links for the entire backplane stack

What is required for this design?

- a. Upgrade the fiber to single mode or a higher grade multimode.
 - b. Use QSFP BiDi transceivers for the 40 GbE uplinks.
 - c. Use QSFP SR4 transceivers for the stacking connections.
 - d. Deploy more MM OM2 strands to make a total of 24.
4. An architect needs to plan an 802.11ac upgrade for an office building. The customer has requested an active survey. Which approach should the architect take to determine the cell edges?
- a. Set the test AP to the maximum transmit power and use the 2.4 GHz signal to determine the cell edges.
 - b. Set the test AP to the minimum transmit power and use the 2.4 GHz signal to determine the cell edges.
 - c. Set the test AP to the maximum transmit power and use the 5 GHz signal to determine the cell edges.
 - d. Set the test AP to the minimum transmit power and use the 5 GHz signal to determine the cell edges.
5. A customer has high security needs, so the network architect proposes dedicated Air Monitors (AMs). What is one additional benefit of the AMs that the architect can explain?
- a. If a nearby AP fails, the AM can automatically convert to AP mode to fill in the coverage gap.
 - b. The AMs can detect a broad range of RF interference and give administrators help in determining the source.
 - c. During normal operation, the AMs can support clients, as well as detect and mitigate threats on any channel.
 - d. An AM can help in troubleshooting because it stores detailed statistics about wireless traffic locally.

Answers

This section provides answers to and references for the sample questions.

1. A customer needs a wireless refresh for 802.11ac. The customer site has about 3,000 wireless devices, and the network architect plans to propose 200 APs. The architect also plans to propose two Virtual Mobility Controllers (VMCs) and a Virtual Mobility Master (VMM). Which licenses should the architect propose for this solution?
 - a. Four LIC-MM-VA-1K; Four LIC-MC-VA-50; 200 Enterprise
 - b. Five LIC-MM-VA-50; Four LIC-MC-VA-50; 200 Enterprise

- c. Five LIC-MM-VA 50; Four LIC-MC-VA 50 and no Enterprise required
- d. Five LIC-MM-VA-50; 200 Enterprise and no LIC-MC-VA required

2. For which scenario does an Aruba VIA client provide the solution?

- a. A customer needs an easy-to-use wireless solution that enables remote workers to connect to the same SSID at the corporate office and at home.
- b. A customer has many telecommuters who take laptops on and offsite and needs a solution to check the security compliance and health of these laptops.
- c. A customer needs to let traveling workers connect to the Internet anywhere and receive secure access to the main site.**
- d. A customer needs a client that will simplify connections to the wireless network at the main site no matter what type of authentication the SSID requires.

3. Refer to the exhibit.

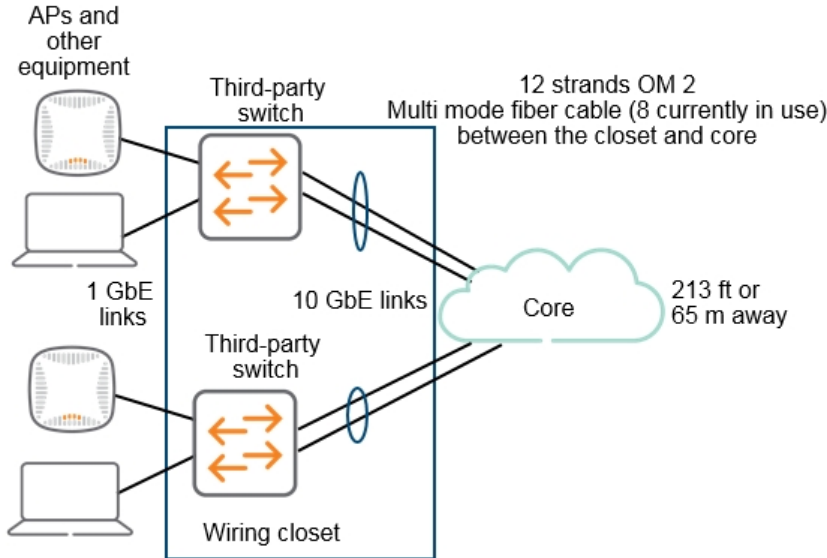

The exhibit shows information about a customer's existing equipment in a closet. The customer needs an upgrade for this closet. The architect plans to:

- Replace the switches with two Aruba 3810M switches
- Connect the 3810M switches in a backplane stack
- Upgrade the uplinks to two 40GbE links for the entire backplane stack

What is required for this design?

- a. Upgrade the fiber to single mode or a higher grade multimode.**
- b. Use QSFP BiDi transceivers for the 40 GbE uplinks.
- c. Use QSFP SR4 transceivers for the stacking connections.
- d. Deploy more MM OM2 strands to make a total of 24.

4. An architect needs to plan an 802.11ac upgrade for an office building. The customer has requested an active survey. Which approach should the architect take to determine the cell edges?

- a. Set the test AP to the maximum transmit power and use the 2.4 GHz signal to determine the cell edges.
- b. Set the test AP to the minimum transmit power and use the 2.4 GHz signal to determine the cell edges.
- c. Set the test AP to the maximum transmit power and use the 5 GHz signal to determine the cell edges.
- d. Set the test AP to the minimum transmit power and use the 5 GHz signal to determine the cell edges.**

5. A customer has high security needs, so the network architect proposes dedicated Air Monitors (AMs). What is one additional benefit of the AMs that the architect can explain?

- a. If a nearby AP fails, the AM can automatically convert to AP mode to fill in the coverage gap.
- b. The AMs can detect a broad range of RF interference and give administrators help in determining the source.
- c. During normal operation, the AMs can support clients, as well as detect and mitigate threats on any channel.
- d. An AM can help in troubleshooting because it stores detailed statistics about wireless traffic locally.

For more information

Contact our program

© Copyright 2020 Hewlett Packard Enterprise. The information contained herein is subject to change without notice. The only warranties for HPE products and services are set forth in the express warranty statements accompanying such products and services. Nothing herein should be construed as constituting an additional warranty. HPE shall not be liable for technical or editorial errors or omissions contained herein.

Information is as of February 2020, Revision 5